

SPECIFICATIONS

AIR SOCKET SWITCH ANW2540



Air Socket Switch ANW2540

Benefits/features

- Suitable for kitchen waste disposal, swimming pools, hot springs, cleaning equipment, etc
- Use as remote control device that works in conjunction with pneumatic buttons
- Only for indoor use

Basic information

Gas tightness	Under 50psi pressure,no leakage phenomenon
Pressure range	<130mbar(180psi)
Switching load	15A at 120VAC
Dielectric strength	1500V
Temperature	Ambient:-10... +60°C [14...140°F]
Air tube	Air tube length optional
Tests / Admissions	UL 60730(the Standard for Safety For Industrial Control Equipment)

*RoHS-compliant products are assigned separate material numbers. Please ensure careful selection when placing an order.

Dimensions in mm [in]

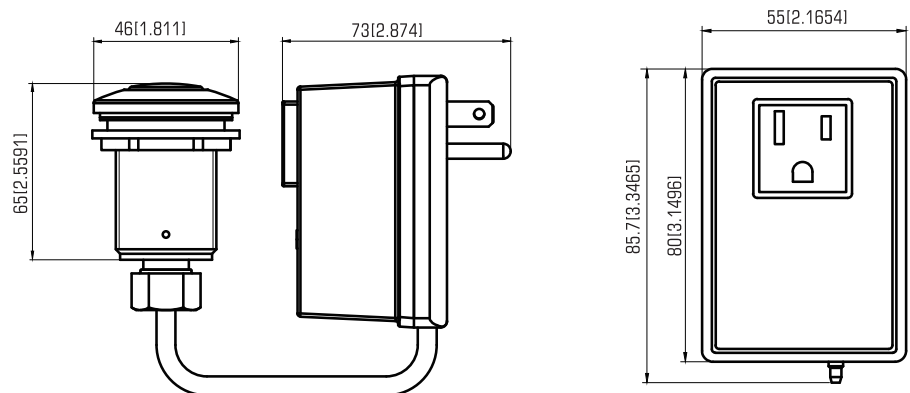

ORDER CODE SELECTION TABLE & USAGE

AIR SOCKET SWITCH ANW2540



Nickel plating



Matte black



Stainless steel mirror finish



PVD coating on brass surface

Air Socket Switch ANW2540

Name	Button Type	Button
ANW2540	A	S

A=M28 short button
B=M32 short button
C=M32 long button

N=Nickel plating
B=Matte black
S=Stainless steel mirror finish
O=PVD coating on brass surface
(Other colors can contact the factory)

Usage diagram

